

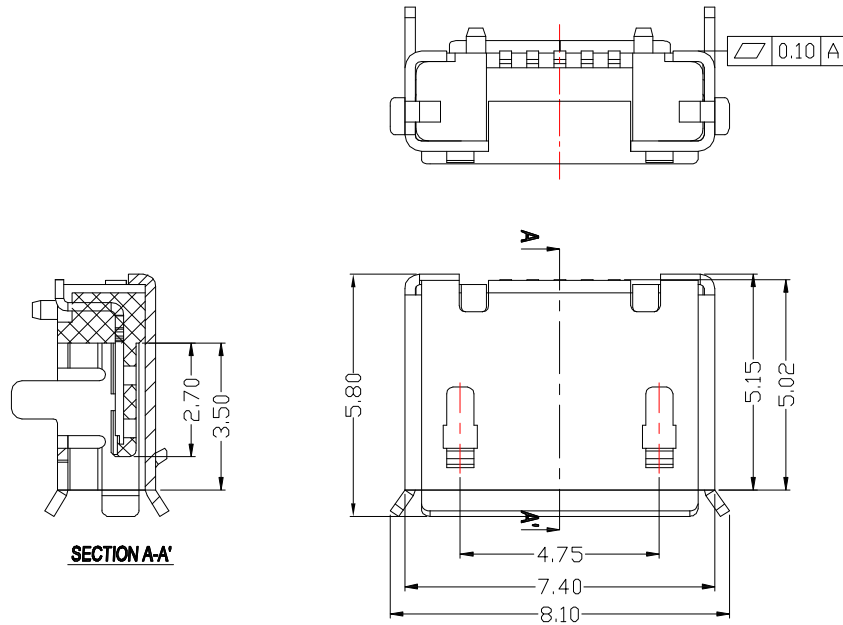

MRUSB-5B-ED1x-S347

SHELL 鍍層:

TN
NI



SECTION A-A'

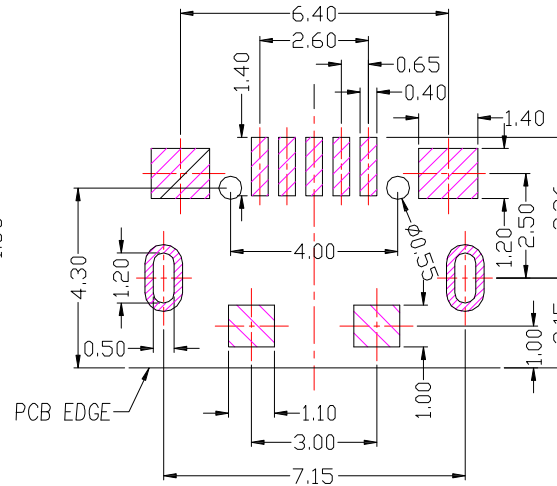
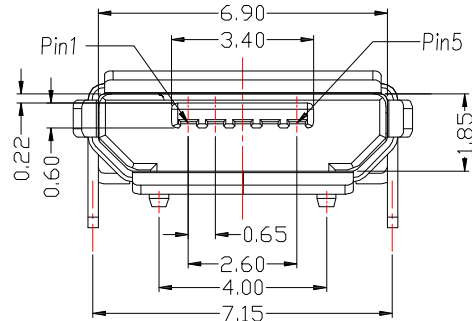
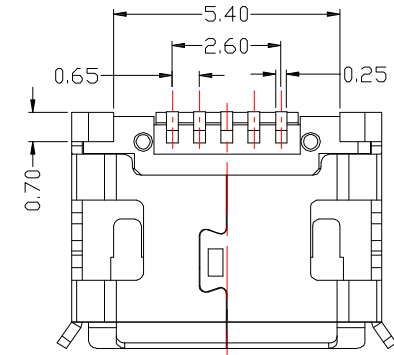
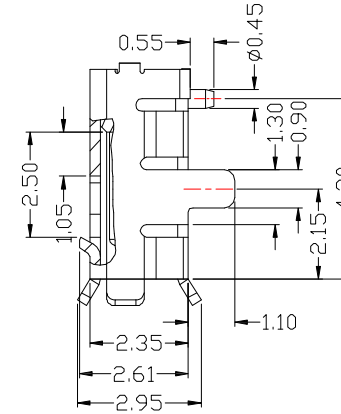

P.C.B LAYOUT MOUNTING PATTERN

NOTES:

MATERIAL:

- 1.1 HOUSING: LCP, UL94V-0
- 1.2 CONTACT: PHOSPHOR BRONZE
- 1.3 SHELL: BRASS

Finish:

- 2.1 CONTACT: PLATED GOLD IN MATING AREA ;
GOLD PLATED ON SOLDER BALLS ;
NICKEL UNDER PLATED OVERALL
- 2.2 SHELL: TIN UNDER PLATED SURFACE LAYER
OR NICKEL UNDER PLATED SURFACE LAYER

3.SPECIFICATION:

- 3.1 CURRENT RATING: 1.0 A MAX
- 3.2 DIELECTRIC WITHSTANDING VOLTAGE: 100 V(ac) FOR 1min
- 3.3 CONTACT RESISTANCE: 30 mΩ MAX.
- 3.4 INSULATION RESISTANCE: 100 MΩ MIN.
- 3.5 TOTAL MATING FORCE: 3.57 Kgf MAX.
- 3.6 TOTAL UNMATING FORCE: 1.0 Kgf MIN.
- 3.7 TEMPERATURE RANGE: -30°C ~ +80°C

東莞市高迪電子有限公司
DONG GUAN GAO DI ELECTRONICS CO., LTD

TOLERANCE UNLESS OTHERWISE STATED:

Up to 5 ±0.2
Above 5 ~ 15 ±0.3
Above 15 ~ 30 ±0.4
Above 30 ~ 50 ±0.5
Angle ±0.3°

3RD. ANGEL'S



UNITS MM

DRAWN BY: Jack Lu
CHECKED BY: Jacky Chen
APPROVED BY: Tony Kao

DATE: 04/17/19
DATE: 04/17/19
DATE: 04/17/19

MAT'L
FINISH
SCALE
SHEET NO.

1 of 1

TITLE
MODLE
DWG NO.
PART NO.

CONNECTOR
MICRO USB 5B/F SMT 插板7.15
腳長 1.10,有柱 有捲邊
MRUSB-5B-ED1x-S347
MRUSB-5B-ED1x-S347

SIZE
A4
VER
R3

ITEM NO.	DESCRIPTION	DRAWN	DATE
3	更新樣式	Lan	041719
2	更新底部樣式	Jack	012119
1	新增尺寸	Jack	031218